



22136508

**PHYSICS
HIGHER LEVEL
PAPER 2**

Monday 6 May 2013 (morning)

2 hours 15 minutes

Candidate session number

0	0								
---	---	--	--	--	--	--	--	--	--

Examination code

2	2	1	3	-	6	5	0	8
---	---	---	---	---	---	---	---	---

INSTRUCTIONS TO CANDIDATES

- Write your session number in the boxes above.
- Do not open this examination paper until instructed to do so.
- Section A: answer all questions.
- Section B: answer two questions.
- Write your answers in the boxes provided.
- A calculator is required for this paper.
- A clean copy of the *Physics Data Booklet* is required for this paper.
- The maximum mark for this examination paper is [95 marks].



0140

Please **do not** write on this page.

Answers written on this page
will not be marked.



SECTION A

Answer **all** questions. Write your answers in the boxes provided.

A1. Data analysis question.

A particular semiconductor device generates an emf, which varies with light intensity. The diagram shows the experimental arrangement which a student used to investigate the variation with distance d of the emf ε . The power output of the lamp was constant. (The power supply for the lamp is not shown.)

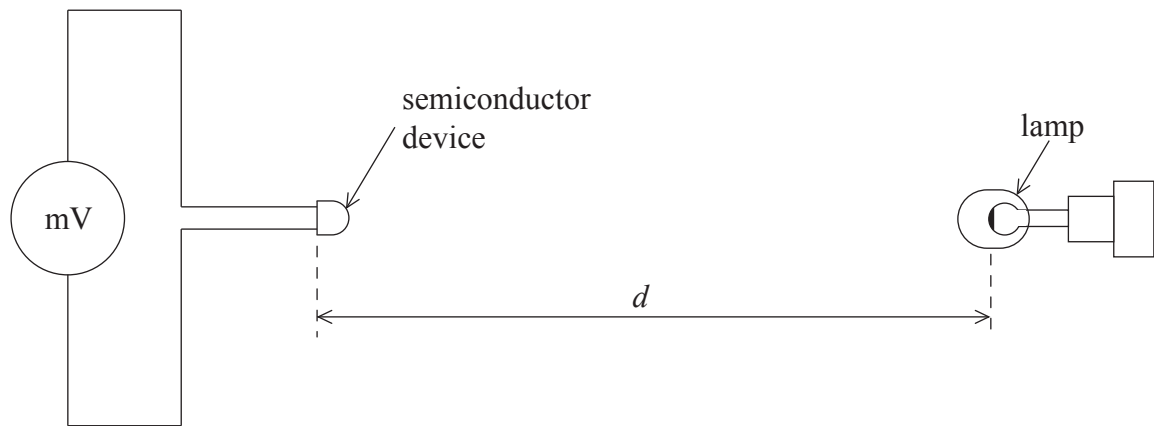

The table shows how ε varied with d .

d / cm	ε / mV
19.1	5.5
18.0	6.0
16.0	8.6
14.0	11.9
12.0	19.7
10.0	37.5

- (a) Outline why the student has recorded the ε values to different numbers of significant digits but the same number of decimal places. [2]

.....

.....

.....

.....

(This question continues on the following page)



(Question A1 continued)

- (b) The graph shows some of the data points with the uncertainty in the d values.

On the graph

- (i) draw the data point corresponding to the value of $d = 19.1$ cm. [1]
- (ii) assuming that there is a constant absolute uncertainty in measuring all values of d , draw the error bar for the data point in (b)(i). [1]
- (iii) sketch the line of best-fit for all the plotted points. [1]

(This question continues on the following page)



(Question A1 continued)

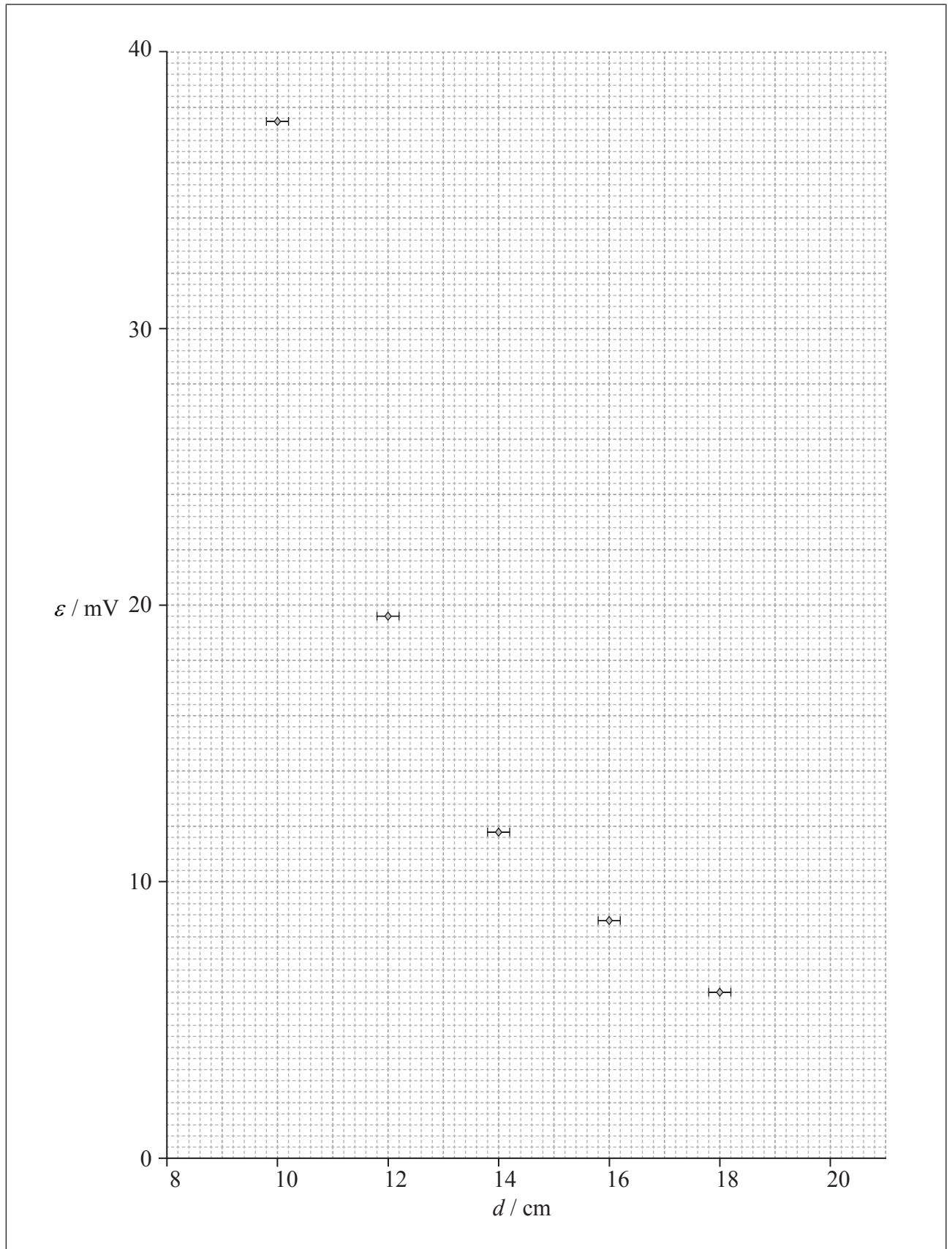

(This question continues on the following page)



0540

Turn over

(Question A1 continued)

- (c) All values of ε have a percentage uncertainty of $\pm 3\%$. Calculate the percentage uncertainty in the product $d\varepsilon$ for the value of $d = 18.0$ cm. [2]

.....

.....

.....

.....

- (d) The student hypothesises that there may be an exponential relationship between ε and d of the form shown below, where a and k are constants.

$$\varepsilon = ae^{-kd}$$

- (i) Deduce a suitable unit for k . [1]

.....

.....

- (ii) Suggest the graph that the student should plot in order to get a straight-line graph if the hypothesis is valid. [2]

.....

.....

.....

.....

- (iii) Explain how k can be obtained from the graph in (d)(ii). [1]

.....

.....



A2. This question is about circular motion.

The diagram shows a car moving at a constant speed over a curved bridge. At the position shown, the top surface of the bridge has a radius of curvature of 50 m.

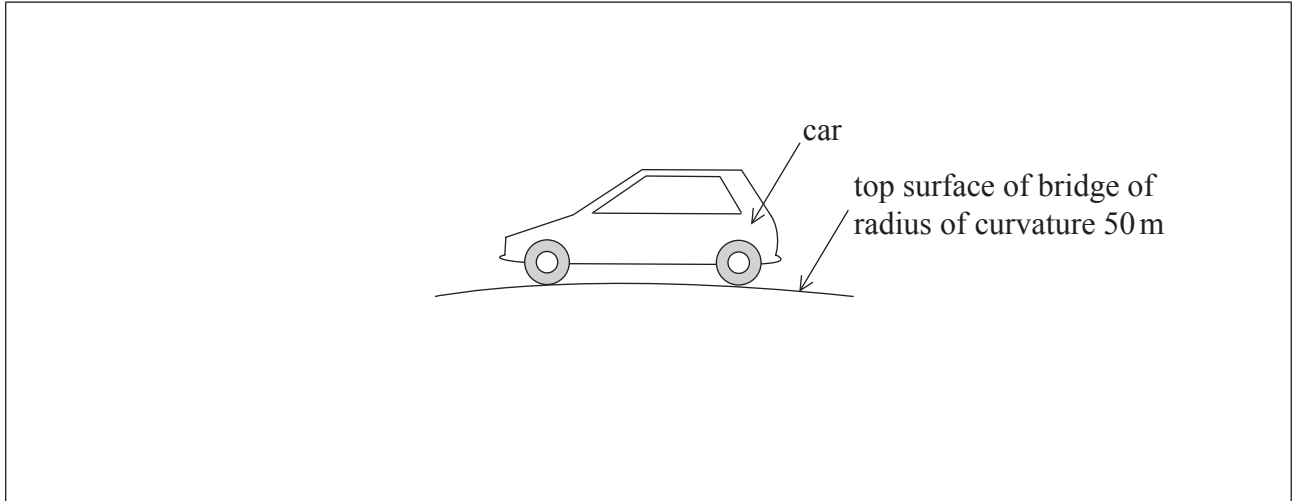

(a) Explain why the car is accelerating even though it is moving with a constant speed. [2]

.....

.....

.....

.....

.....

(b) On the diagram, draw and label the vertical forces acting on the car in the position shown. [2]

(c) Calculate the maximum speed at which the car will stay in contact with the bridge. [3]

.....

.....

.....

.....

.....

.....



A3. This question is about the superposition of waves.

(a) State what is meant by the principle of superposition of waves.

[1]

.....

.....

.....

.....

(b) The diagram shows two point sources of sound, X and Y. Each source emits waves of wavelength 1.1 m and amplitude A . Over the distances shown, any decrease in amplitude can be neglected. The two sources vibrate in phase.

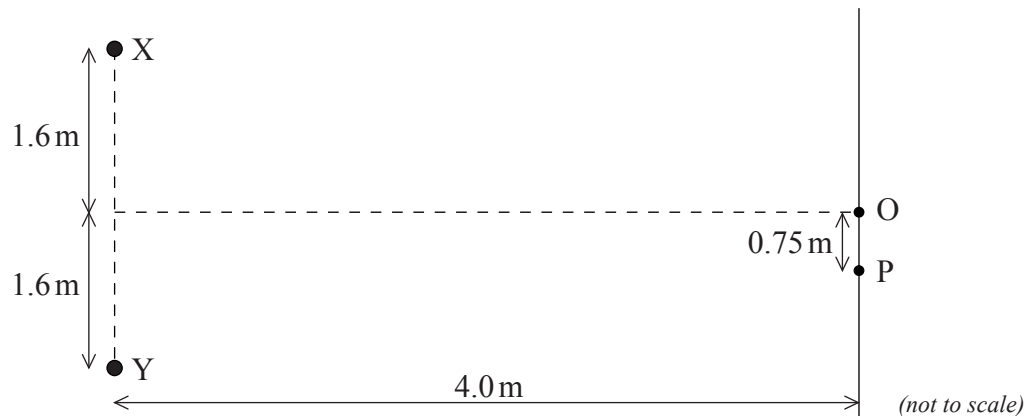

Points O and P are on a line 4.0 m from the line connecting X and Y. O is opposite the midpoint of XY and P is 0.75 m from O.

(i) Explain why the intensity of the sound at O is $4A^2$.

[2]

.....

.....

.....

(This question continues on the following page)



(Question A3 continued)

(ii) Deduce that no sound is detected at P.

[3]

.....

.....

.....

.....

.....

.....



A4. This question is about impulse and momentum.

The diagram shows an arrangement used to test golf club heads.

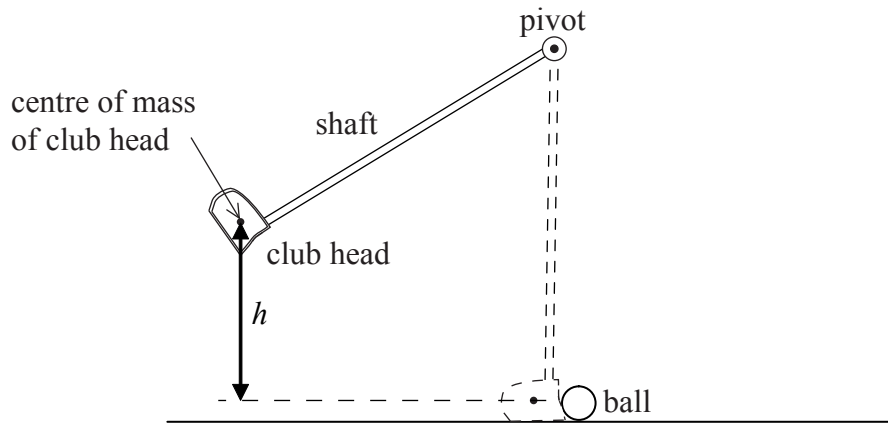

The shaft of a club is pivoted and the centre of mass of the club head is raised by a height h before being released. On reaching the vertical position the club head strikes the ball.

- (a) (i) Describe the energy changes that take place in the club head from the instant the club is released until the club head and the ball separate. [2]

.....

.....

.....

.....

- (ii) Calculate the maximum speed of the club head achievable when $h=0.85$ m. [2]

.....

.....

.....

.....

(This question continues on the following page)



(Question A4 continued)

- (b) The diagram shows the deformation of a golf ball and club head as they collide during a test.

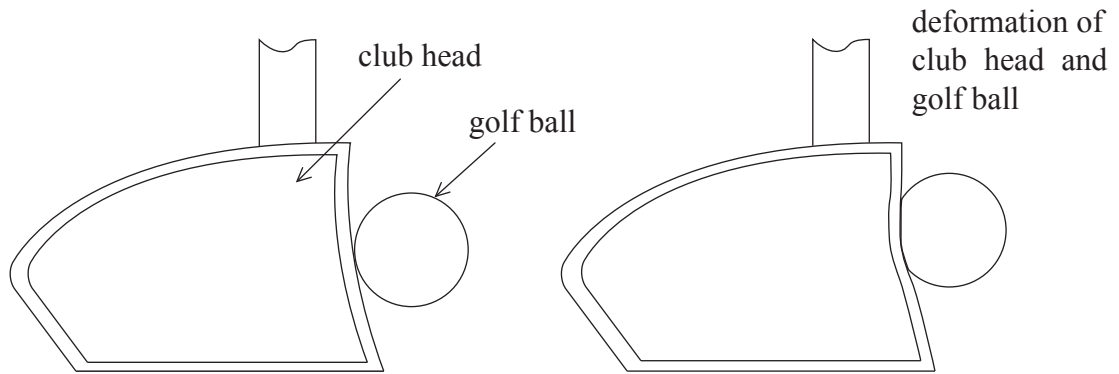

Explain how increasing the deformation of the club head may be expected to increase the speed at which the ball leaves the club. [2]

.....

.....

.....

.....

(This question continues on the following page)



(Question A4 continued)

(c) In a different experimental arrangement, the club head is in contact with the ball for a time of $220 \mu\text{s}$. The club head has mass 0.17 kg and the ball has mass 0.045 kg . At the moment of contact the ball is at rest and the club head is moving with a speed of 38 m s^{-1} . The ball moves off with an initial speed of 63 m s^{-1} .

(i) Calculate the average force acting on the ball while the club head is in contact with the ball. [2]

.....
.....
.....
.....

(ii) State the average force acting on the club head while it is in contact with the ball. [1]

.....
.....

(iii) Calculate the speed of the club head at the instant that it loses contact with the ball. [2]

.....
.....
.....
.....



Please **do not** write on this page.

Answers written on this page
will not be marked.



1340

Turn over

A5. This question is about simple harmonic motion and forced oscillations.

The graph shows the variation with time of the displacement of an object undergoing simple harmonic motion.

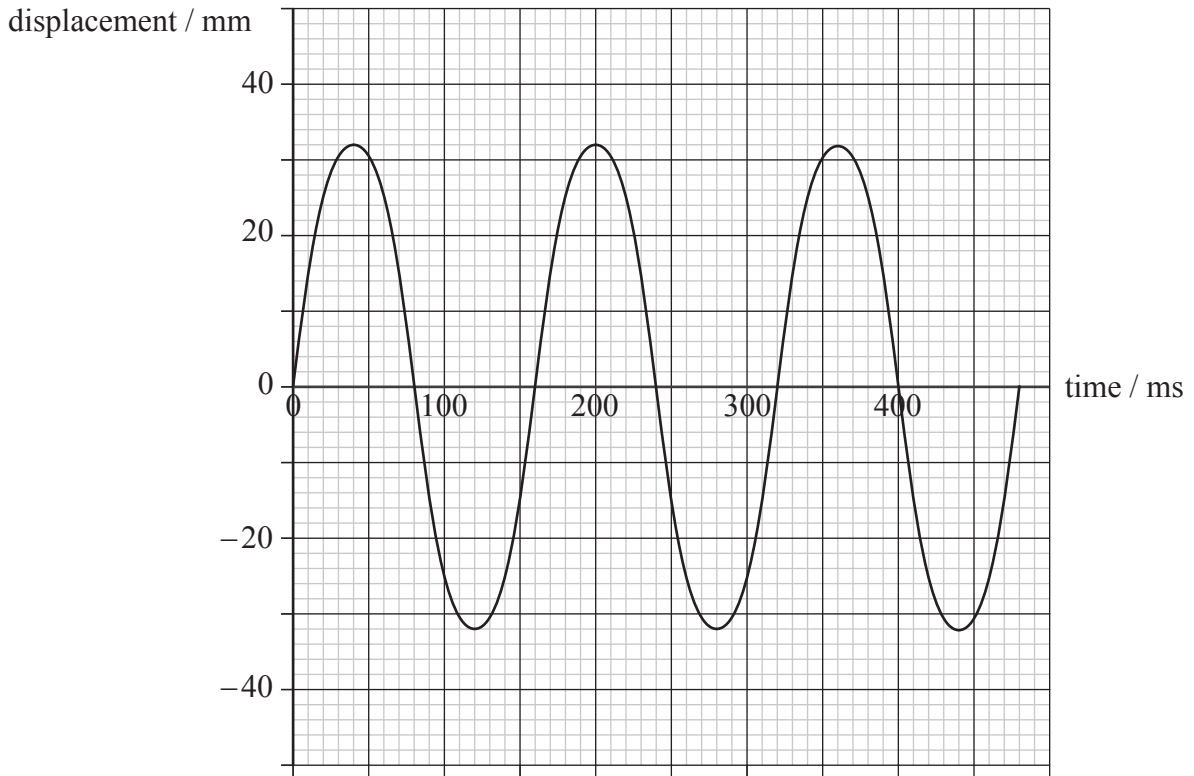

(a) (i) State the amplitude of the oscillation. [1]

.....
.....

(ii) Calculate the frequency of the oscillation. [2]

.....
.....
.....

(This question continues on the following page)



(Question A5 continued)

(b) (i) Determine the maximum speed of the object.

[2]

.....
.....
.....
.....

(ii) Determine the acceleration of the object at 140 ms.

[2]

.....
.....
.....
.....

(c) The graph below shows how the displacement of the object varies with time. Sketch on the same axes a line indicating how the kinetic energy of the object varies with time. You should ignore the actual values of the kinetic energy.

[3]

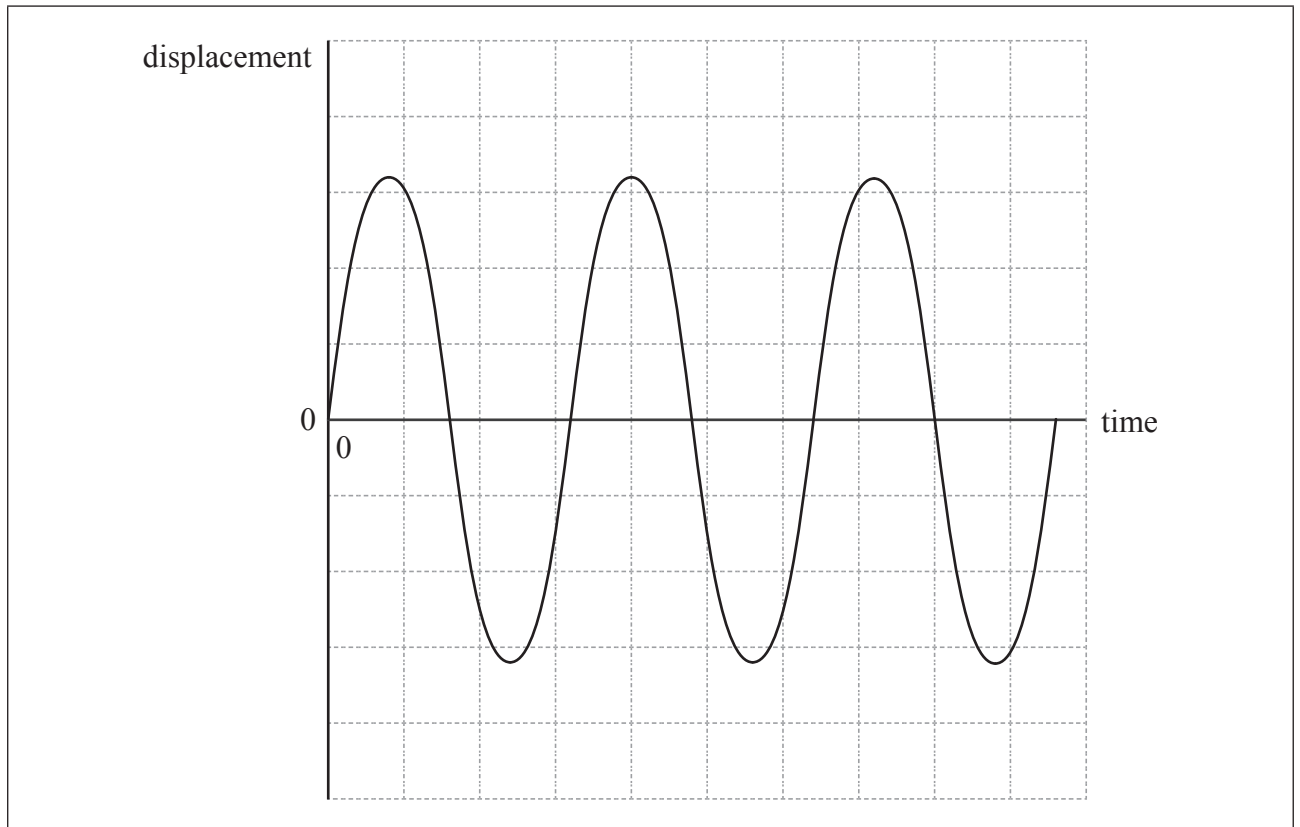

SECTION B

*This section consists of four questions: B1, B2, B3 and B4. Answer **two** questions. Write your answers in the boxes provided.*

B1. This question is in **two** parts. **Part 1** is about electromagnetic induction. **Part 2** is about nuclear fusion.

Part 1 Electromagnetic induction

(a) A bar magnet falls vertically from rest through a coil of wire. The potential difference (pd) across the coil is recorded by a datalogger.

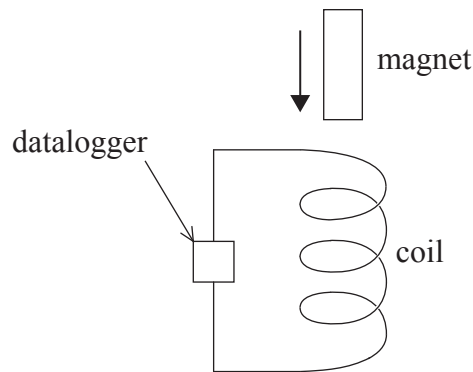

The graph shows the variation with time of the pd across the coil.

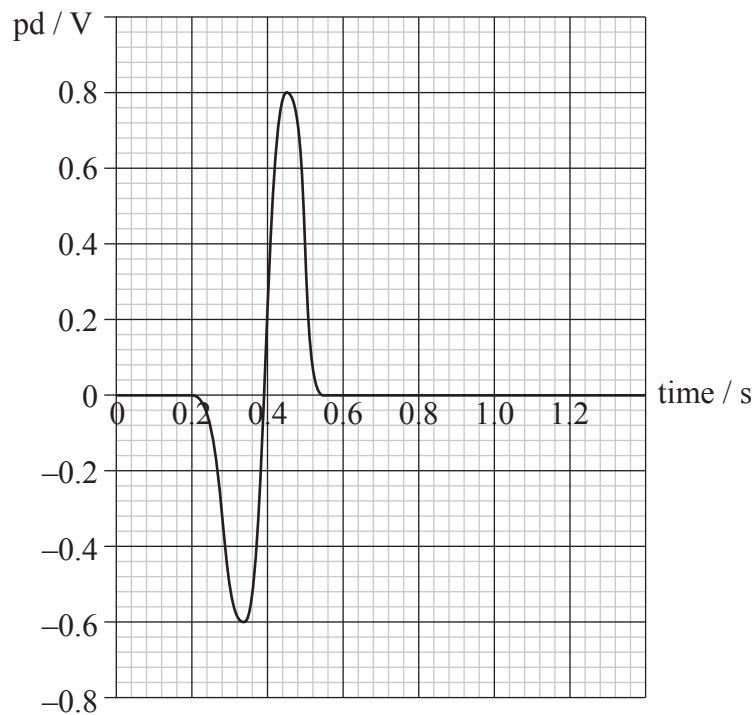

(This question continues on the following page)



(Question B1, part 1 continued)

- (i) Explain, with reference to Faraday's and Lenz's laws, the shape of the graph. [3]

.....

.....

.....

.....

.....

.....

- (ii) The coil has 1500 turns. Calculate the magnitude of the maximum rate of change of magnetic flux. [3]

.....

.....

.....

.....

.....

(This question continues on the following page)



(Question B1, part 1 continued)

(b) The magnet is now suspended from a spring. The magnet is displaced vertically and starts to oscillate in and out of the coil. A sinusoidal alternating current of rms value 280 nA is induced in the coil.

(i) State in words how the rms value of the alternating current relates to a direct current of 280 nA. [1]

.....

.....

.....

(ii) The coil has a resistance of $1.5\text{ M}\Omega$. Calculate the peak voltage across the coil. [2]

.....

.....

.....

.....

.....

.....

(iii) Explain what effect the generation of the current has on the oscillation of the magnet. [2]

.....

.....

.....

.....

(This question continues on page 20)



Please **do not** write on this page.

Answers written on this page
will not be marked.



(Question B1 continued)

Part 2 Nuclear fusion

The diagram shows the variation of nuclear binding energy per nucleon with nucleon number for some of the lighter nuclides.

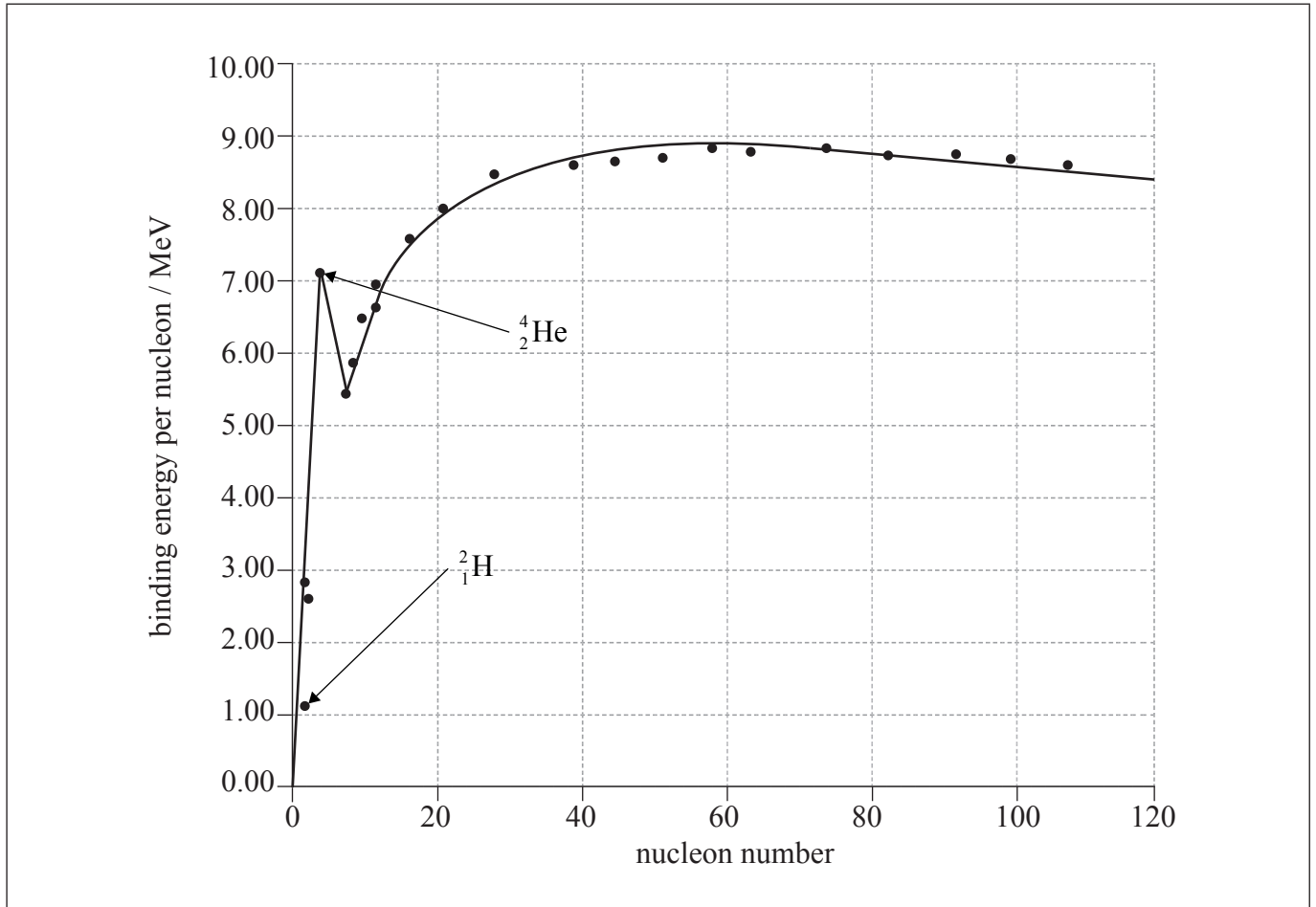

- (a) (i) Outline, with reference to mass defect, what is meant by the term nuclear binding energy. [2]

.....
.....
.....
.....

- (ii) Label, with the letter S, the region on the graph where nuclei are most stable. [1]

(This question continues on the following page)



(Question B1, part 2 continued)

- (iii) Show that the energy released when two ${}^2_1\text{H}$ nuclei fuse to make a ${}^4_2\text{He}$ nucleus is approximately 4 pJ. [4]

.....

.....

.....

.....

.....

.....

.....

.....

- (b) In one nuclear reaction two deuterons (hydrogen-2) fuse to form tritium (hydrogen-3) and another particle. The tritium undergoes β^- decay to form an isotope of helium.

- (i) Identify the missing particles to complete the equations. [4]

$${}^2_1\text{H} + {}^2_1\text{H} \rightarrow {}^3_1\text{H} + \dots\dots\dots$$

$${}^3_1\text{H} \rightarrow \dots\text{He} + \dots\dots\dots + \dots\dots\dots$$

- (ii) Explain which of these reactions is more likely to occur at high temperatures. [3]

.....

.....

.....

.....

.....

.....

.....

.....



B2. This question is in **two** parts. **Part 1** is about photoelectricity. **Part 2** is about electrical and magnetic force fields.

Part 1 Photoelectricity

(a) State what is meant by work function.

[1]

.....
.....
.....

(b) The diagram shows part of an experimental arrangement used to investigate the photoelectric effect.

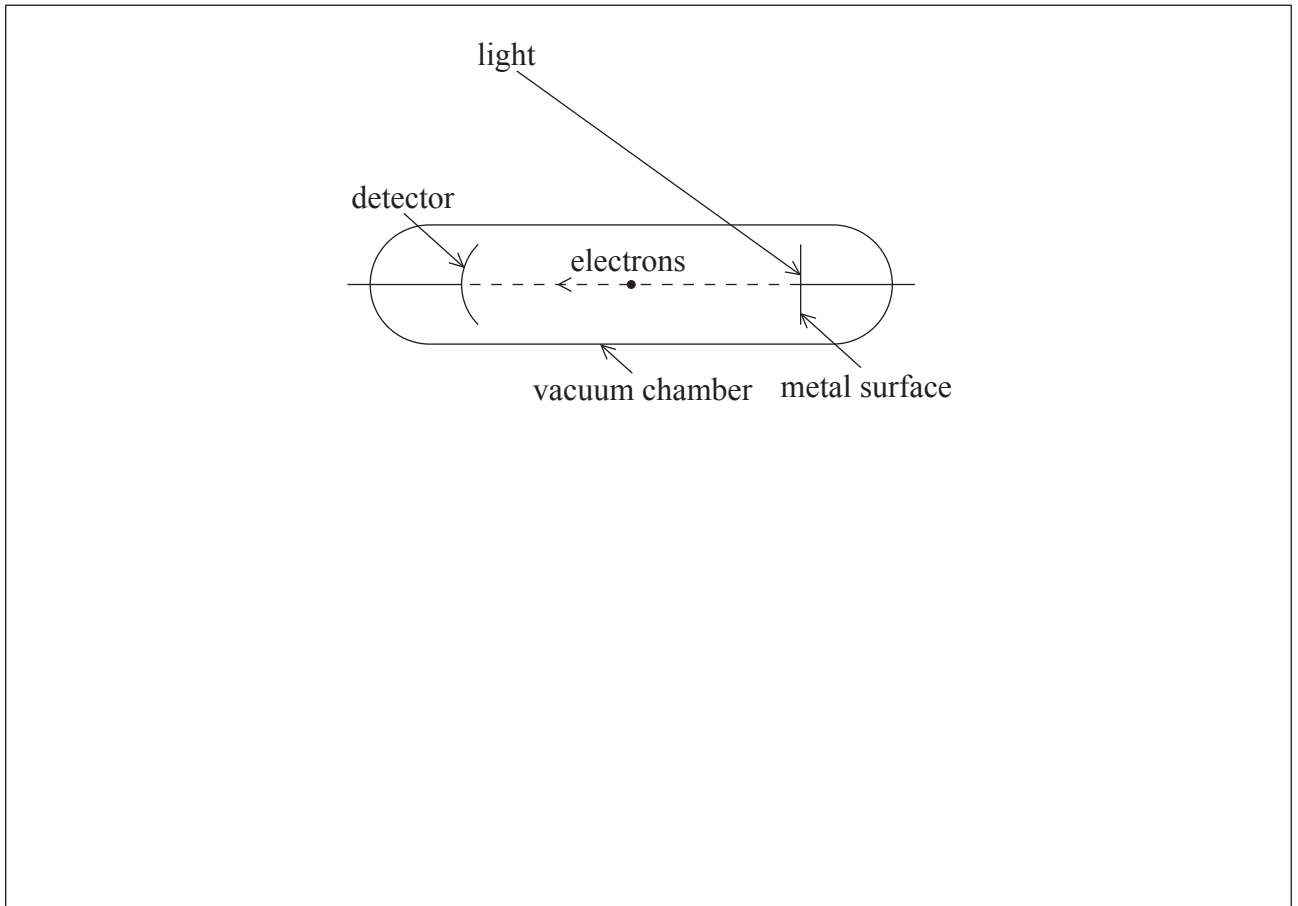

(This question continues on the following page)



(Question B2, part 1 continued)

- (i) Explain how the maximum kinetic energy of the emitted electrons is determined experimentally. [2]

.....

.....

.....

.....

.....

.....

- (ii) On the diagram, draw the power supply and other necessary components needed in order to carry out the experiment in (b)(i). [2]

(This question continues on the following page)



(Question B2, part 1 continued)

- (c) Using results obtained with the apparatus in (b), the following graph was drawn. The graph shows how the maximum kinetic energy of the photoelectrons varies with the frequency of the incident radiation.

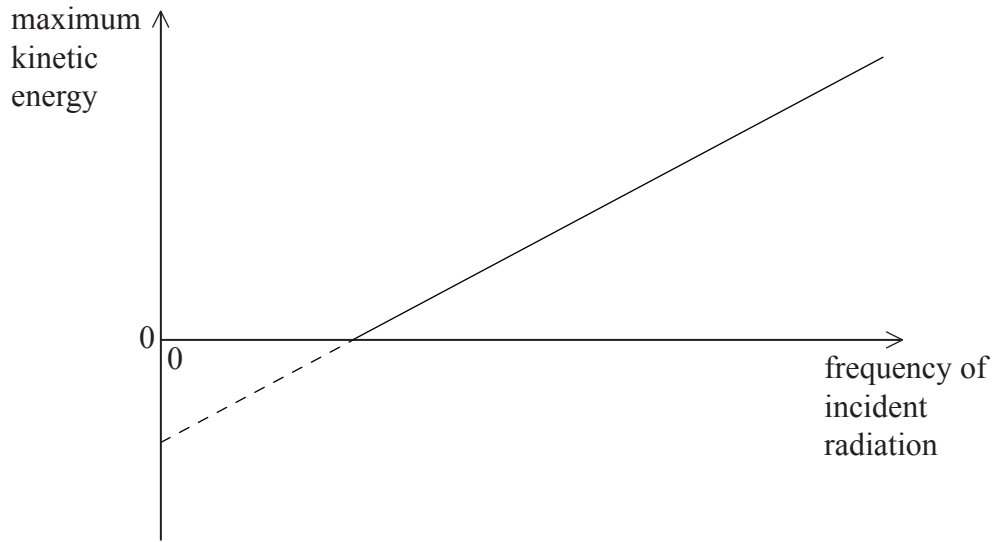

State how the graph can be used to determine

- (i) a value for the Planck constant.

[1]

.....
.....
.....

- (ii) the work function of the material.

[1]

.....
.....
.....

(This question continues on the following page)



(Question B2, part 1 continued)

(iii) the threshold wavelength of the material.

[1]

.....

(d) In an experiment, light at a particular frequency is incident on a surface and electrons are emitted. Explain what happens to the number of electrons emitted per second when the intensity of this light is increased.

[2]

.....

(This question continues on the following page)



(Question B2 continued)

Part 2 Electric and magnetic force fields

- (a) Define *electric field strength*. [2]

.....
.....
.....
.....

- (b) The diagram shows a pair of horizontal metal plates. Electrons can be deflected vertically using an electric field between the plates.

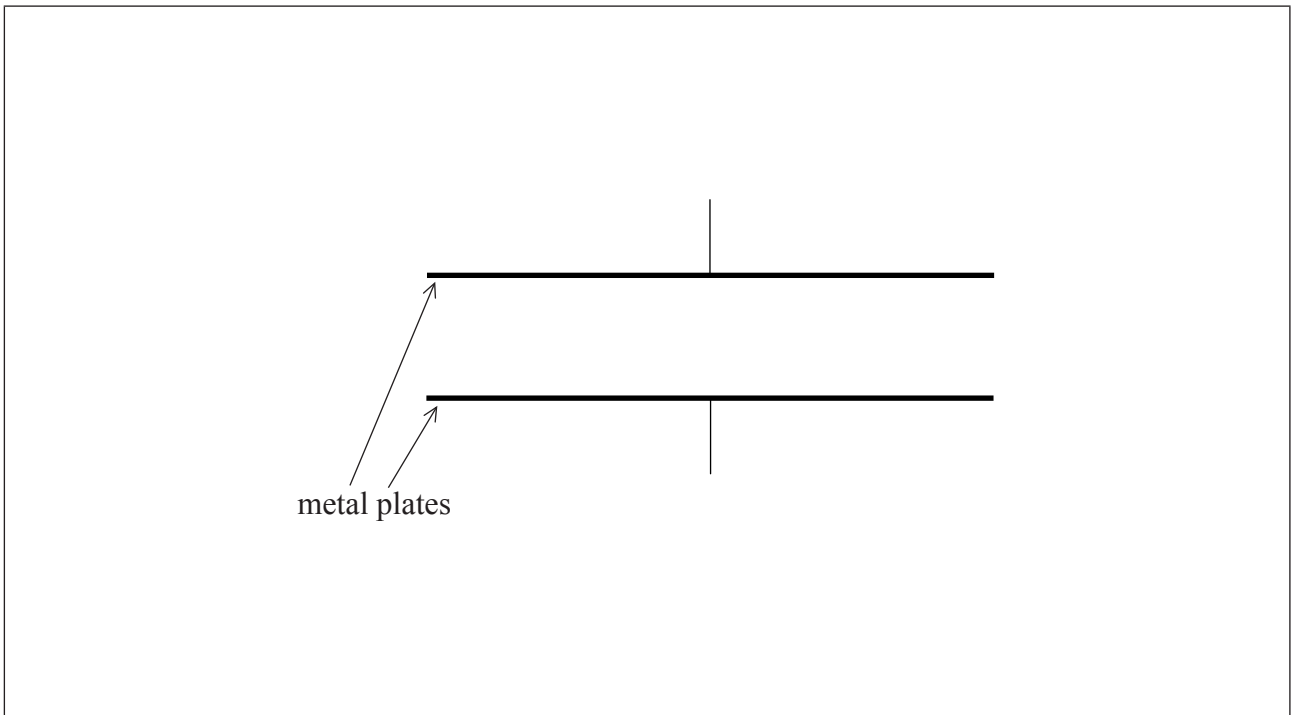

- (i) Label, on the diagram, the polarity of the metal plates which would cause an electron positioned between the plates to accelerate upwards. [1]
- (ii) Draw the shape and direction of the electric field between the plates on the diagram. [2]

(This question continues on the following page)



(Question B2, part 2 continued)

- (iii) Calculate the force on an electron between the plates when the electric field strength has a value of $2.5 \times 10^3 \text{ N C}^{-1}$. [2]

.....
.....
.....
.....

- (c) The diagram shows two isolated electrons, X and Y, initially at rest in a vacuum. The initial separation of the electrons is 5.0 mm. The electrons subsequently move apart in the directions shown.

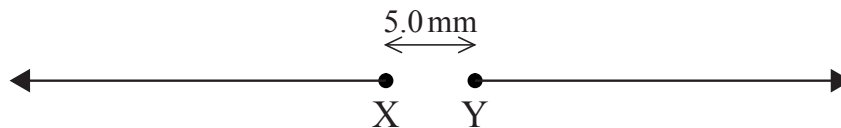

- (i) Show that the initial electric force acting on each electron due to the other electron is approximately $9 \times 10^{-24} \text{ N}$. [2]

.....
.....
.....
.....

- (ii) Calculate the initial acceleration of one electron due to the force in (c)(i). [1]

.....
.....

(This question continues on the following page)



(Question B2, part 2 continued)

(iii) Discuss the motion of one electron after it begins to move.

[3]

.....
.....
.....
.....
.....
.....
.....
.....

(iv) The diagram shows Y as seen from X, at one instant. Y is moving into the plane of the paper. For this instant, draw on the diagram the shape and direction of the magnetic field produced by Y.

[2]

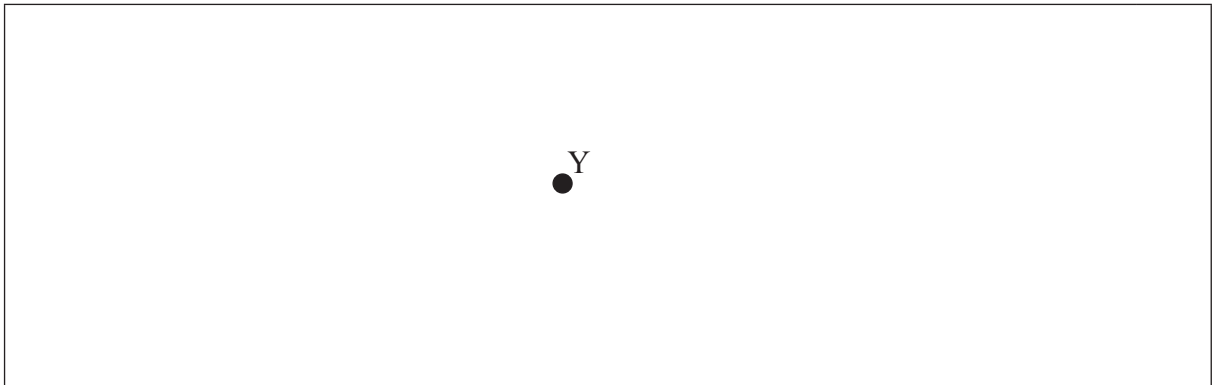

B3. This question is about alternative energy supplies.

A small island community requires a peak power of 850 kW. Two systems are available for supplying the energy: using wind power or photovoltaic cells.

- (a) (i) Outline, with reference to the energy conversions in the machine, the main features of a conventional horizontal-axis wind generator. [3]

.....

.....

.....

.....

.....

- (ii) The mean wind speed on the island is 8.0 ms^{-1} . Show that the maximum power available from a wind generator of blade length 45 m is approximately 2 MW. [2]

Density of air = 1.2 kg m^{-3}

.....

.....

.....

.....

- (iii) The efficiency of the generator is 24%. Deduce the number of these generators that would be required to provide the islanders with enough power to meet their energy requirements. [2]

.....

.....

.....

.....

(This question continues on the following page)



(Question B3 continued)

- (b) The graph below shows how the wind speed varies with height above the land and above the sea.

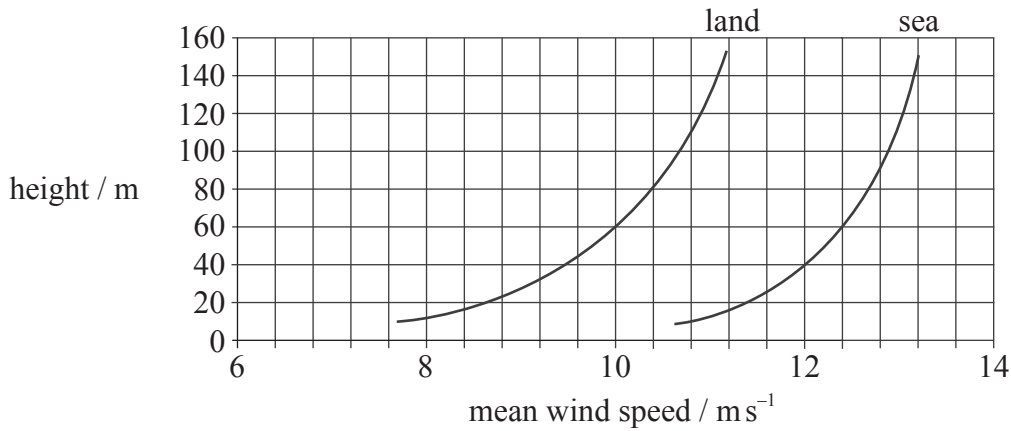

- (i) Suggest why, for any given height, the mean wind speed above the sea is greater than the mean wind speed above the land. [1]

.....

.....

- (ii) There is a choice of mounting the wind generators either 60m above the land or 60m above the sea.

Calculate the ratio

$$\frac{\text{power available from a land-based generator}}{\text{power available from a sea-based generator}}$$

at a height of 60m.

[2]

.....

.....

.....

.....

(This question continues on the following page)



(Question B3 continued)

(c) Distinguish between photovoltaic cells and solar heating panels.

[2]

.....
.....
.....
.....

(This question continues on the following page)



(Question B3 continued)

- (d) The diagram shows 12 photovoltaic cells connected in series and in parallel to form a module to provide electrical power.

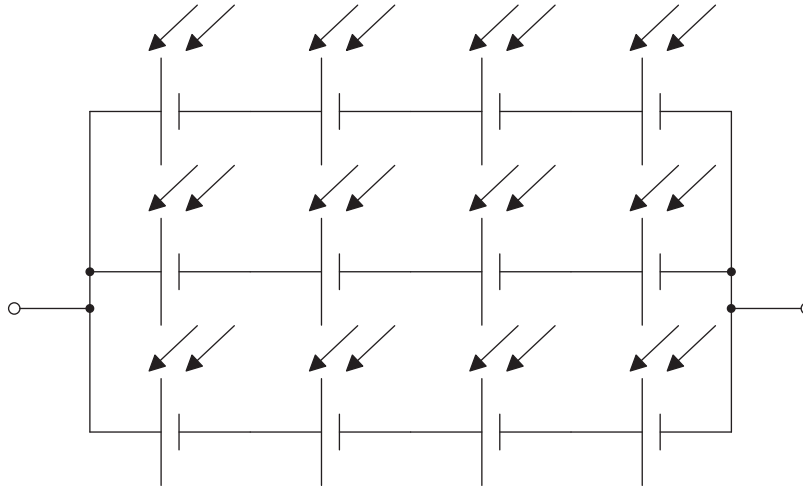

Each cell in the module has an emf of 0.75 V and an internal resistance of 1.8 Ω.

- (i) Calculate the emf of the module. [1]

.....

.....

- (ii) Determine the internal resistance of the module. [3]

.....

.....

.....

.....

.....

.....

(This question continues on the following page)



(Question B3 continued)

- (iii) The diagram below shows the module connected to a load resistor of resistance 2.2Ω .

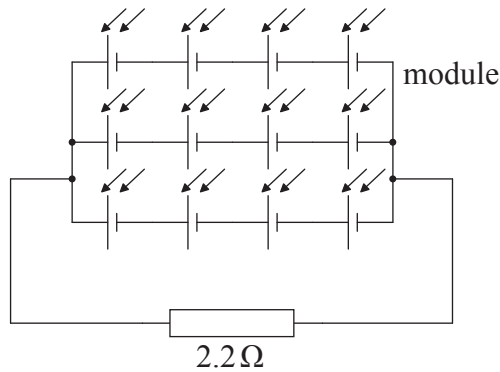

Calculate the power dissipated in the load resistor.

[2]

.....

.....

.....

.....

- (iv) Discuss the benefits of having cells combined in series and parallel within the module.

[2]

.....

.....

.....

.....

.....

.....

(This question continues on the following page)



(Question B3 continued)

(e) The intensity of the Sun’s radiation at the position of the Earth’s orbit (the solar constant) is approximately $1.4 \times 10^3 \text{ W m}^{-2}$.

(i) Explain why the average solar power per square metre arriving at the Earth is $3.5 \times 10^2 \text{ W}$. [2]

.....

.....

.....

.....

.....

.....

(ii) State why the solar constant is an approximate value. [1]

.....

.....

.....

(iii) Photovoltaic cells are approximately 20% efficient. Estimate the minimum area needed to supply an average power of 850 kW over a 24 hour period. [2]

.....

.....

.....

.....



B4. This question is in **two** parts. **Part 1** is about gravitational force fields. **Part 2** is about properties of a gas.

Part 1 Gravitational force fields

(a) State Newton’s universal law of gravitation. [2]

.....
.....
.....

(b) A satellite of mass m orbits a planet of mass M . Derive the following relationship between the period of the satellite T and the radius of its orbit R (Kepler’s third law). [3]

$$T^2 = \frac{4\pi^2 R^3}{GM}$$

.....
.....
.....
.....
.....
.....
.....

(This question continues on the following page)



(Question B4, part 1 continued)

- (c) A polar orbiting satellite has an orbit which passes above both of the Earth's poles. One polar orbiting satellite used for Earth observation has an orbital period of 6.00×10^3 s.

Mass of Earth = 5.97×10^{24} kg
Average radius of Earth = 6.37×10^6 m

- (i) Using the relationship in (b), show that the average height above the surface of the Earth for this satellite is about 800 km. [3]

.....
.....
.....
.....
.....

- (ii) The satellite moves from an orbit of radius 1200 km above the Earth to one of radius 2500 km. The mass of the satellite is 45 kg.

Calculate the change in the gravitational potential energy of the satellite. [3]

.....
.....
.....
.....

- (iii) Explain whether the gravitational potential energy has increased, decreased or stayed the same when the orbit changes, as in (c)(ii). [2]

.....
.....
.....
.....

(This question continues on the following page)



(Question B4 continued)

Part 2 Properties of a gas

- (a) With respect to a gas, explain the meaning of the terms thermal energy and internal energy. [2]

<p>Thermal energy:</p> <p>.....</p> <p>Internal energy:</p> <p>.....</p>
--

(This question continues on the following page)



(Question B4, part 2 continued)

- (b) The graph shows how the pressure P of a sample of a fixed mass of an ideal gas varies with volume V . The gas is taken through a cycle **ABCD**.

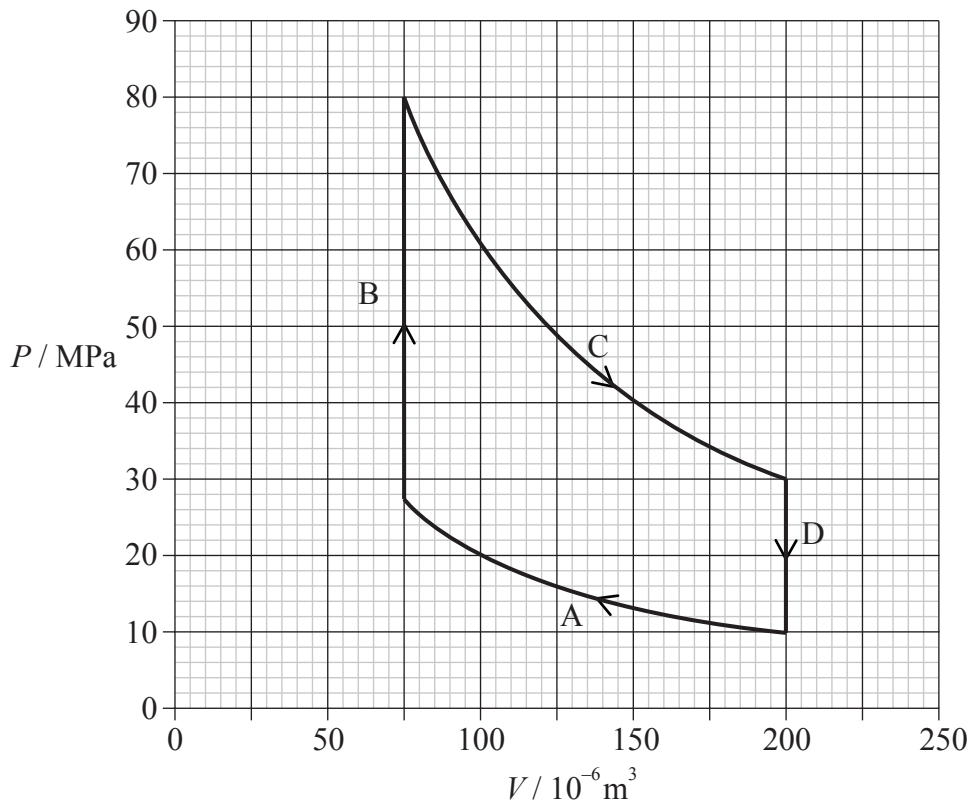

- (i) Estimate the net work done during the cycle. [3]

.....

.....

.....

.....

.....

- (ii) Explain whether the net work is done on the gas or by the gas. [1]

.....

.....

.....

(This question continues on the following page)



(Question B4, part 2 continued)

(iii) Deduce, using the data from the graph, that the change **C** is isothermal. [2]

.....
.....
.....
.....
.....

(iv) Isothermal change **A** occurs at a temperature of 450 K. Calculate the temperature at which isothermal change **C** occurs. [2]

.....
.....
.....
.....
.....

(v) Describe the changes **B** and **D**. [2]

B:
.....
D:
.....



Please **do not** write on this page.

Answers written on this page
will not be marked.



4040